

Herby's Angel

Easy-to-carve figure is a Holiday delight

by Paul McLeod

Herby Ham designed his angel with beginner carvers in mind.



materials & tools

MATERIALS:

2½" x 3½" x 5½" basswood block (angel)
¼" x ¾" x 1¼" basswood scrap (book)
Finish of choice (I use boiled linseed oil)

TOOLS:

Carving knife of choice (I use a 2¼" blade)
⅛" and ⅝" V-tools (outlining hair, shawl, and sash)
¾" 45° V-tool (groove in outside of wings)
#11 ⅛" and #11 ¼" gouges (pleats in skirt and shawl)
#9 ¼" fishtail gouge (top inside of wings)
#5 and #7 ½" gouges (inside of wings)

This charming angel was designed by Herby Ham. Herby is responsible for starting my love affair with carving wood and I know that he would be honored to have the piece featured in the magazine to inspire other carvers.

I met Herby in the late 1990s while wintering in Uvalde, TX. Herby had renovated a large building with donated materials and labor and turned it into a Senior Center with more than 3,000 square feet dedicated to the wood shop.

My wife and I decided to stay for awhile, and I spent most of my time helping other "winter Texans" with their woodworking projects and repairing various woodworking machines. Herby finally convinced me to try woodcarving. Of course I said what most people say—I can't do that. He encouraged me to give it a shot and with his guidance, I discovered a new hobby, and have been carving ever since.

Sometime later, I found out that

my step mother's aunt was Herby's grandmother. I suppose that made us "kissin' cousins." Herby died several years ago, and my wife and I stayed in Uvalde helping out at the center. Herby's wife, Nancy, gave me permission to use Herby's Angel for my woodcarving teaching and sales and for publication. The angel is a tribute to a fine man who helped many folks discover the joy of woodcarving.

Carving Herby's Angel

Herby's Angel is carved out of a solid block of wood. Herby would cut out the side-view pattern on the bandsaw, but would carve the other profiles. Herby's method took two days of hard carving to finish the angel. Since I teach with Herby's Angel, I had roughouts made, so it only takes one day of moderately hard carving to finish it.

No special tools are needed to carve the angel; however, a scoop-type (fishtail) short-bent gouge helps with the inside of the wings.

Other than the wings, the angel is not difficult to carve.

Carve the outside of the wings first. Do not make the insides of the wings concave near the edge; it makes them more difficult to carve. A uniform curve from the inside edge to the back of the shawl is the best way to carve the wings.

The book that may be placed in the Angel's hands was the idea of Norman "Norm" Rutledge, one of the participants in my angel carving class at the North Arkansas Woodcarvers Club in Mountain Home, AK.



About the Author

Paul retired from the faculty of The University of Arkansas At Little Rock in 1998. He and his wife sold their house and went on the road in an RV. In addition

to giving classes, Paul loves to attend seminars with other carvers and has learned from many instructors. His favorite instructors include Dallas Deege and Gerald Sears. For more of his work, visit www.whiterivercrafts.com.

Back

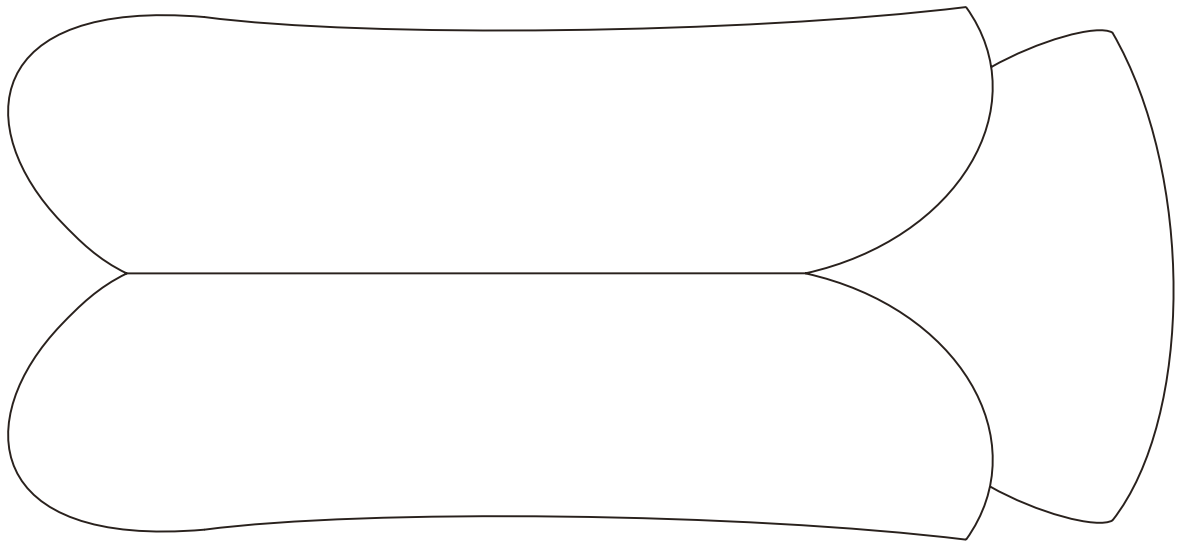

© 2006 Fox Chapel Publishing Co., Inc. *Wood Carving Illustrated* Designer: Herby Ham Illustrator: Toni Burghout

Front

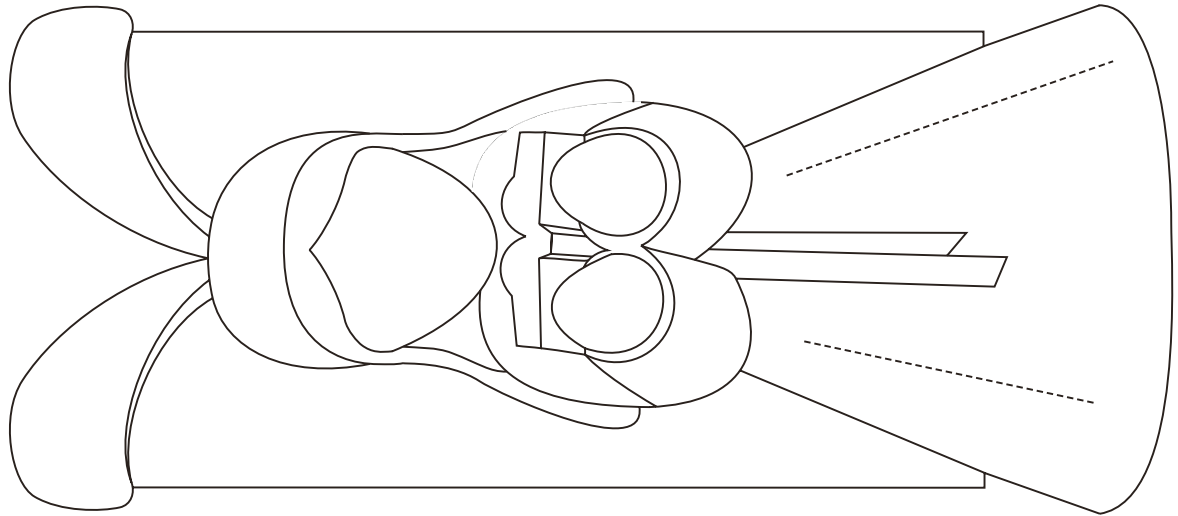

Side

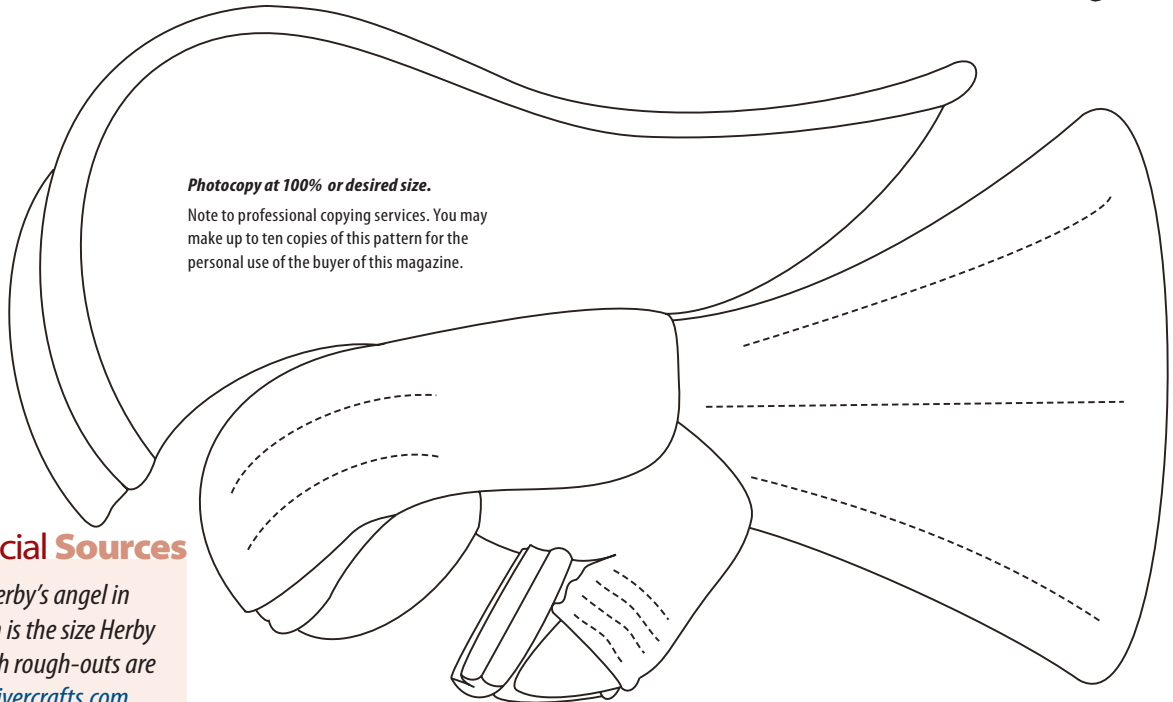

Photocopy at 100% or desired size.

Note to professional copying services. You may make up to ten copies of this pattern for the personal use of the buyer of this magazine.

Special Sources

Paul has roughouts for Herby's angel in two sizes; 5½"-tall, which is the size Herby carved, and 9¼"-tall. Both rough-outs are available at www.whiterivercrafts.com, 870-942-5695.